

ASSEMBLING AND  
USING YOUR

*Heathkit*

Vacuum Tube Voltmeter  
Model V-5A



THE HEATH COMPANY  
BENTON HARBOR, MICH.

## USEFUL INFORMATION FOR KIT BUILDERS

Resistors are identified by a color code used in several bands around the resistors. There are two general types of resistors. One, the un-insulated type, has the connecting wires bound around the ends. The other, the insulated type, has the wire connected internally and coming out the ends. The resistance code uses three bands or colors, while a fourth, usually silver or gold, indicates the tolerance. The colors are arranged so that the first two indicate the first two figures of the resistance, while the third indicates the number of digits (zeros or multiplier) which follow the first two figures. On un-insulated resistors, the body is the first figure, the end color the second figure, and the dot the number of digits. On insulated resistors, the band nearest the end is the first figure, the next band is the second figure and the third band the number of digits.

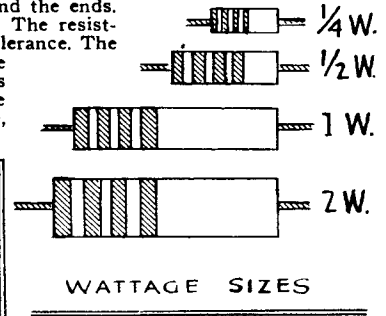

**WATTAGE.** Resistors are rated as to wattage (power dissipation) according to size. The chart shows approximate sizes which vary with manufacturers. To determine wattage size necessary multiply current through resistor in amperes by voltage drop across resistor in volts. Example — A plate loading resistor for a tube drawing 10 milli-amperes (.01 Amperes) has a voltage on one side of 300 volts and on the other side 200 volts, giving a drop of 100 volts. Therefore 100 volts  $\times$  .01A. = 1 Watt.  
A higher wattage resistor can always be substituted for smaller size.

Uninsulated Insulated	Body Color First Ring	End Color Second Ring	Dot Color Third Ring
Color	First Figure	Second Figure	Number of Digits
Black	0	0	None
Brown	1	1	0
Red	2	2	00
Orange	3	3	000
Yellow	4	4	0.000
Green	5	5	0.0000
Blue	6	6	00.0000
Violet	7	7	0.000.000
Grey	8	8	00.000.000
White	9	9	000.000.000

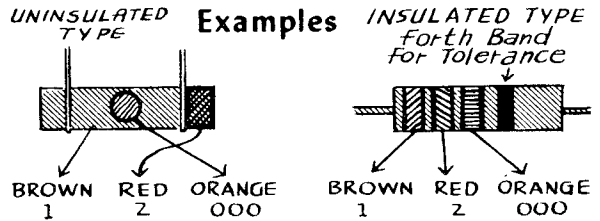

### Some Popular Sizes of Resistors

RESISTANCE IN OHMS	BODY OR FIRST BAND	END OR SECOND BAND	DOT OR THIRD BAND
50	Green	Black	Black
250	Red	Green	Brown
1500	Brown	Green	Red
30,000	Orange	Black	Orange
220,000	Red	Red	Yellow
1 Megohm	Brown	Black	Green

The fourth ring or other end may be silver (10% tolerance) or gold (5% tolerance) or it may be omitted entirely which indicates 20% tolerance.

### Condenser Code

Condensers use the same code as resistors and are read in micromicrofarads.

If there is one row of dots, they are read in direction of arrow or if manufacturer's name appears in the same direction as name. If two rows of dots appear, it can either be of two different codes: The RMA or the AWS (American War Standard). In the RMA, the top row of dots are the first three figures (carried to three figures), the bottom row are left to right the voltage rating, tolerance, and decimal multiplier.

In the AWS code, the top row of dots are the first three figures while the bottom row are, left to right, characteristic, tolerance, and decimal multiplier.

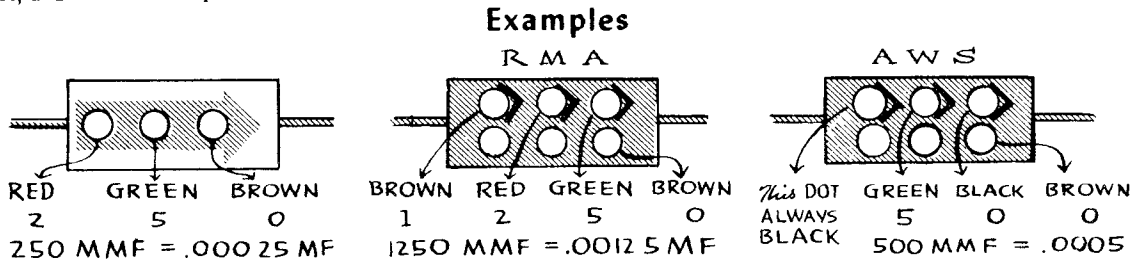

### Some Commonly Used Sizes of Condensers

MMF.	MF.	FIRST DOT	SECOND DOT	THIRD DOT
10	.00001	Brown	Black	Black
50	.00005	Green	Black	Black
100	.0001	Brown	Black	Brown
250	.00025	Red	Green	Brown
500	.0005	Green	Black	Brown
1000	.001	Brown	Black	Red
3000	.003	Orange	Black	Red
10,000	.01	Brown	Black	Orange

The tolerance rating corresponds to the color code, i.e., red — 2%, green — 5%, etc.

The voltage rating corresponds to the code multiplied by 100. Example: Orange dot — 300 volt rating; Blue — 600 volt rating.

# HEATHKIT VTVM . . . . MODEL V-5A



## SPECIFICATIONS

Power Requirements:	105-125V 50/60 Cycle AC, 10 Watts.
Cabinet Size:	7 3/8" high x 4 11/16" wide x 4 1/8" deep.
Kit Shipping Weight:	5 pounds
Meter:	4 1/2" Streamlined case with 200 microampere movement.
Multipliers:	Precision type.
Tubes:	1 - 6H6 Twin triode meter bridge. 1 - 7A6 Twin diode AC rectifier.
Power Supply:	Power transformer and selenium rectifier.
Battery:	1 1/2 Volt flashlight cell.
D. C. Voltmeter: 6 Ranges:	0-3, 10, 30, 100, 300, 1,000 volts full scale. With accessory probe to 30,000 Volts.
Input Resistance:	11 megohms (1 megohm in probe) on all ranges. 1,100 megohms with accessory probe.
Sensitivity:	3,666,666 ohms per volt on 3 Volt range.
Circuit:	Balanced bridge (push-pull) using twin triode.
Electronic AC Voltmeter: 6 Ranges:	0-3, 10, 30, 100, 300, 1,000 Volts full scale on linear scales reading R. M. S. (.707 of positive peak).
Circuit:	Diode with adjustable compensation.
Electronic Ohmmeter: 6 Ranges:	Scale with 10 ohms center x1, x10, x100, x1,000, x10K, x1 Meg. Measures .1 ohm to 1,000 megohms with internal battery.

# ASSEMBLY AND USE OF THE HEATHKIT VTVM . . . . MODEL V-5A

**PRELIMINARY NOTES AND INSTRUCTIONS:** The Heathkit Model V-5A Vacuum Tube Voltmeter is an excellent instrument and care used in construction will be well repaid. The construction is open and easily accomplished, but it should not be rushed, as poor workmanship can easily result in poor operation.

**UNPACK THE KIT CAREFULLY AND CHECK EACH PART AGAINST THE PARTS LIST.** In so doing, you will become acquainted with the parts. If a shortage is found, attach the inspection slip to your claim, and notify us promptly. Screws, nuts, and washers are counted mechanically, and if a few are missing, please secure them locally. Use the charts on the inside covers of this manual to identify the parts.

Read the manual completely through before starting actual construction; in this way, you will become familiar with the general procedure used. Study the pictorials and diagrams to get acquainted with the circuit layout and location of parts. When actually assembling and wiring, read the whole article or step through so that no suggestions will be missed.

To facilitate describing the location of parts, tube sockets, controls, terminal strips, etc. have been lettered and are coded. All such numbering and lettering is clearly shown in the figures and when instructions say for example, "Wire to A3" refer to the proper figure, and connect a wire to pin 3 of socket A.

It is recommended that A, B, C, etc. be actually labeled as such on the chassis with a pencil. Lettering on the inside of the chassis where wiring is done will reduce the possibility of making wrong connections.

Tube socket pins are numbered as shown in figure 4. Always read clockwise when the socket is viewed from the bottom.

Read the note on soldering on the inside of the back cover. Make a good mechanical joint of each connection with clean metal to clean metal. Use only good quality rosin core radio type solder. Pastes or acids are difficult to remove and minute amounts left combine with moisture from the air forming a corrosive product. Weeks or months later corrosion may result in untimely failure.

A circuit description is included in the later section of this manual so that those with some knowledge of radio will be able to obtain a clearer picture of the actual functioning of this instrument. It is not expected that those with little radio experience will understand the description completely, but it should be of help in the event that they desire to become more familiar with the circuit operation, and thus learn more from building the kit than just the placing of parts and wiring.

**NOTE: ALL GUARANTEES ARE VOIDED AND WE WILL NOT REPAIR OR SERVICE INSTRUMENTS IN WHICH ACID CORE SOLDER OR PASTES HAVE BEEN USED.**

Small changes in parts may be made by the Heath Company. Any part supplied will work just as well as the part for which it was substituted. By reading the color code on resistors for instance, it will be readily understood that a value of 51,000 ohms is a substitute for the specified 47,000 ohms, etc. provided the specified value is not supplied. Such changes will only be made if the specified parts are unobtainable at the time, and are made to insure a minimum delay in filling your order.

Resistors and controls have a tolerance rating of plus or minus 20% unless otherwise stated. Therefore, a 100K resistor may test between 80K and 120K ohms. The letter K stands for 1000 and M for 1,000,000. Some manufacturers use M for 1000. Consulting the parts list will clarify any parts in question. Thus, a resistor marked 90K = 90,000 ohms etc. Frequently condensers show an even greater variation such as minus 50% to plus 100%. This Heathkit is designed to accommodate such variations.

### STEP BY STEP ASSEMBLY

The construction of the VTVM is broken down into four parts: chassis parts mounting and wiring, panel parts mounting and wiring, wiring common to both chassis and panel, and test and calibration. If the step-by-step procedure is followed with the aid of the figures and pictorials (for proper placement of parts and lead dress) little difficulty should be encountered in construction.

Check off each step in the space provided (✓) as it is completed.

(S) means solder the connection

(NS) means do not solder yet

#### MOUNTING OF PARTS ON CHASSIS

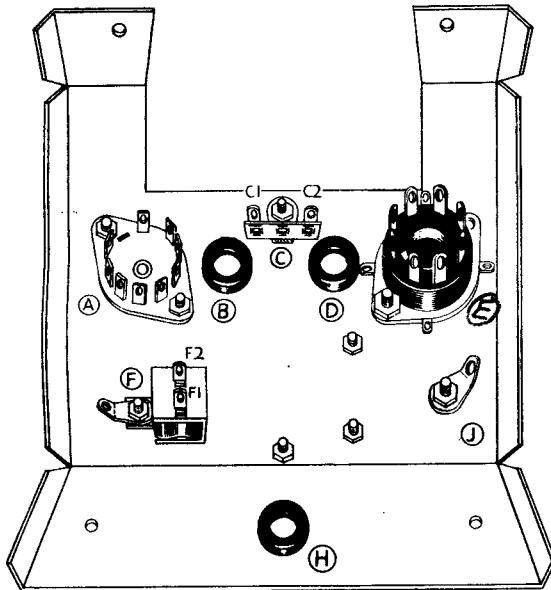

Fig. 1

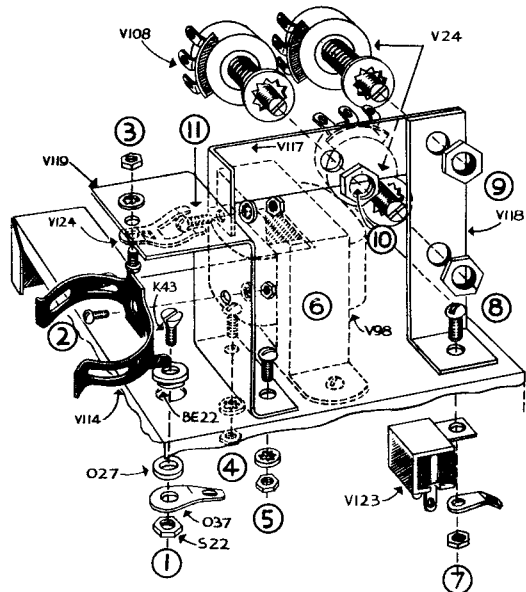

Fig. 2

Observing figure 1;

(✓) Slide a rubber grommet (O35) through hole B in the chassis (V116).

(✓) In a like manner, mount a rubber grommet in position D.

(✓) Next mount a rubber grommet in position H.

(✓) Using 3-48 x 1/4 screws (SW34) and nuts (SW35) (use no lockwashers) mount the miniature tube socket (V113) in location A.

(✓) Using 6-32 screws (O31), lockwashers (TS72), and nuts (S22) mount the octal tube socket (V122) in location E.

Next consult Figure 2 very carefully and note the numbers 1 through 11. If all parts of each step are mounted in sequence, the assembly will go together easily and no parts will interfere with the mounting of parts which follow.

(✓) Step 1. Mount the line up of parts consisting of the flat head screw (K43), the large fibre washer with a shoulder as shown (BE22), the small fibre washer (O27), the solder lug (O37), and a nut.

(✓) Step 2. Mount the battery spring clamp (V114) to the Z angle bracket (V119), by means of a 4-40 screw, lockwasher, and nut.

- (✓) Step 3. Mount the battery base clip (V124) to the Z angle bracket by means of a 4-40 screw, lockwasher, and nut.
- (✓) Step 4. Mount the line up of parts (to hold the Z angle bracket to the chassis) consisting of a 6-32 screw, lockwasher, and nut.
- (✓) Step 5. Mount the line up of parts consisting of a 6-32 screw, lockwasher and nut.
- (✓) Step 6. The power transformer (V98) is next. First pass the two red and the two yellow leads through grommet D, and the two black leads through grommet B. Then,
- (✓) In location C, mount (See Figure 1) the two lug terminal strip (S32) with the 6-32 screw which passes through the transformer mounting flange and chassis, slip on a lockwasher, and fasten with a nut. Next,
- (✓) Fasten the other transformer mounting flange to the chassis by means of a 6-32 screw, lockwasher, and nut.
- (✓) Step 7. Note the + marking on the side of the rectifier (V123). The lug just above this + marking is the positive lug and is designated as lug F2. When mounting the rectifier, be sure that the lugs are oriented as in figures 1 and 2. With a 6-32 screw and nut, mount the shorter L bracket (V118), the rectifier (V123) and a solder lug. (You will observe that one L bracket is shorter than the other.)
- (✓) Step 8. Mount a 10K (this may be marked 10M—note the V24 marking) control (V24) (with lugs in direction as shown in figure 2) with a control lockwasher and nut.

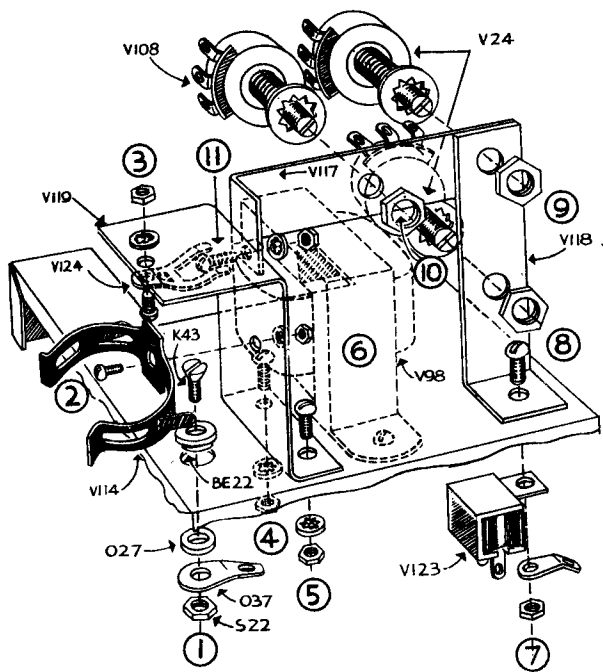

Fig. 2

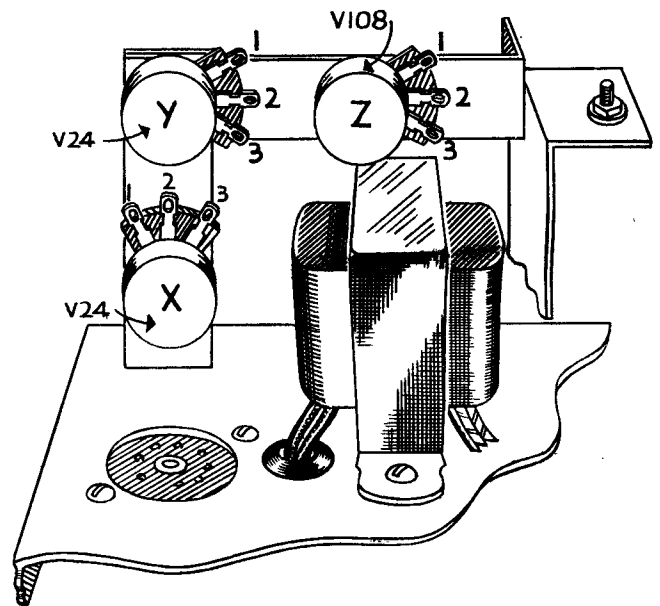

Fig. 3

- (✓) Step 9. Place the long L bracket (V117) flush against the short L bracket and mount a 10K (this may be marked 10M—note the V24 marking) control (V24) with a control lockwasher and nut.
- ( ) Step 10. Mount the 10 megohm control (V108) with a control lockwasher and nut.
- (✓) Step 11. Fasten the long L bracket to the Z bracket by means of a 6-32 screw, lockwasher and nut. (Note figure 3 to make certain that the three above controls are mounted correctly.)

#### WIRING OF CHASSIS

When connecting the transformer leads, before cutting, run each lead to its connecting point and leave sufficient wire for making the connection. Pictorial 1 shows chassis wiring.

- (✓) Connect one red lead of the power transformer to F1 (S).

- ~~Q~~ (✓) Connect the other red lead to C1 (NS) *ok*
- ~~Q~~ (✓) Twist together the two yellow leads and connect one to E2 (NS) *ok*
- ~~Q~~ (✓) The other yellow lead goes to a ground lug on the socket mounting frame as shown in Pictorial 1 (NS). *ok*
- ~~Q~~ (✓) Twist together the two black leads and connect one to C2 (NS). The other black lead should be left unconnected at this time. *ok*
- ~~Q~~ (✓) Pass one lead of a 15K resistor (V23) through A6 (NS) and then connect it to A1 (S). Its other lead connects to the solder lug in location F (NS). *ok*
- ~~Q~~ (✓) Connect a piece of short bare wire to A4 (NS), pass it through A5 (NS), and continue it to the solder lug in location F (NS). *ok*

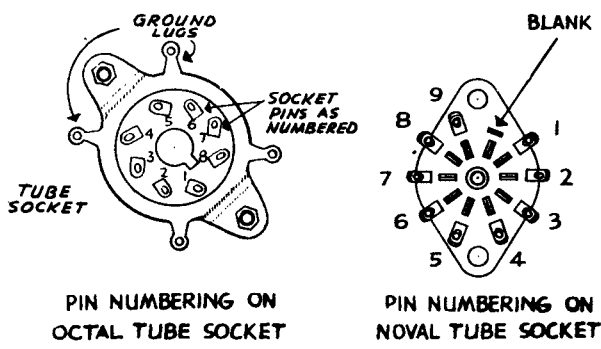

Fig. 4

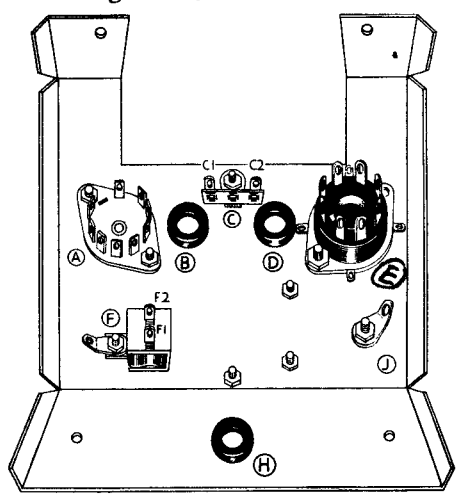
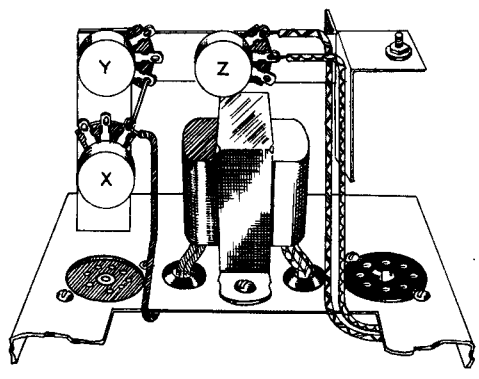
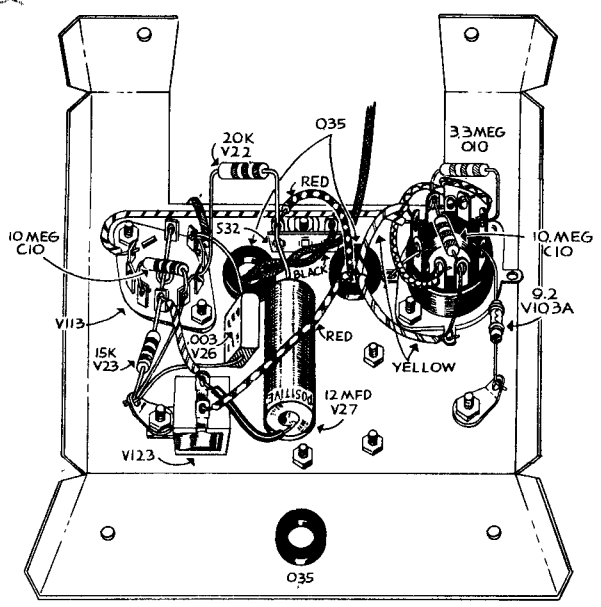

Fig. 1

- ~~Q~~ (✓) Connect a 10 megohm resistor (C10) between A7 (S) and A5 (S) *ok*
- ~~Q~~ (✓) Place the .003 (V26) condenser on edge (see pictorial 1), connect one lead to A2 (NS) and its other lead to the solder lug in location F (S). *ok*
- ~~Q~~ (✓) Run a wire from A9 (S) to E2 (NS). *ok*
- ~~Q~~ (✓) Run a wire from F2 (NS) to A6 (S). *ok*
- ~~Q~~ (✓) Run a wire from A3 (NS) to X3 (NS). *ok*
- ~~Q~~ (✓) Run a short bare wire from X3 (S) to Y3 (S). *ok*
- ~~Q~~ (✓) One lead of a 20K resistor (V22) goes to C1 (NS) and its other lead connects to A4 (S) *ok*
- ~~Q~~ (✓) Note the positive side of the 12 MFD condenser (V27) (Marked POSITIVE OR WITH +++).
- ~~Q~~ (✓) Connect the POSITIVE lead to (use spaghetti) F2 (S) and its other lead to C1 (NS). *ok*



PICTORIAL I  
WIRING OF CHASSIS

- (✓) Run a short bare wire jumper from E1 (S) to the nearby ground lug on the socket mounting frame (S). *ok*
- (✓) Run a short bare wire jumper from E4 (S) to the nearby ground lug on the socket mounting frame (S). *ok*
- (✓) Run a short bare wire jumper from E7 (NS) to the nearby ground lug on the socket mounting frame (S). *ok*
- (✓) Run a wire from E8 (S) to Z2 (S). *ok*
- (✓) Run a wire from E5 (NS) to Z1 (S). *ok*
- (✓) One lead of a 10 megohm resistor connects to E3 (NS) and its other lead goes to E7 (S). *ok*
- (✓) Connect one lead of a 3.3 megohm resistor (O10) to E3 (NS) and its other lead to E5 (S). *ok*
- (✓) One lead of a 9.2 ohm resistor (V103A) goes to E6 (NS) and its other lead goes to the solder lug in location J (S). *ok*

**MOUNTING OF PARTS ON PANEL**

Note Figure 5 for the proper placement of switches, controls, etc. on the panel. Place all contacts and lugs in the same relative positions as shown in the figure. Figure 6 shows the method to use in mounting controls and switches.

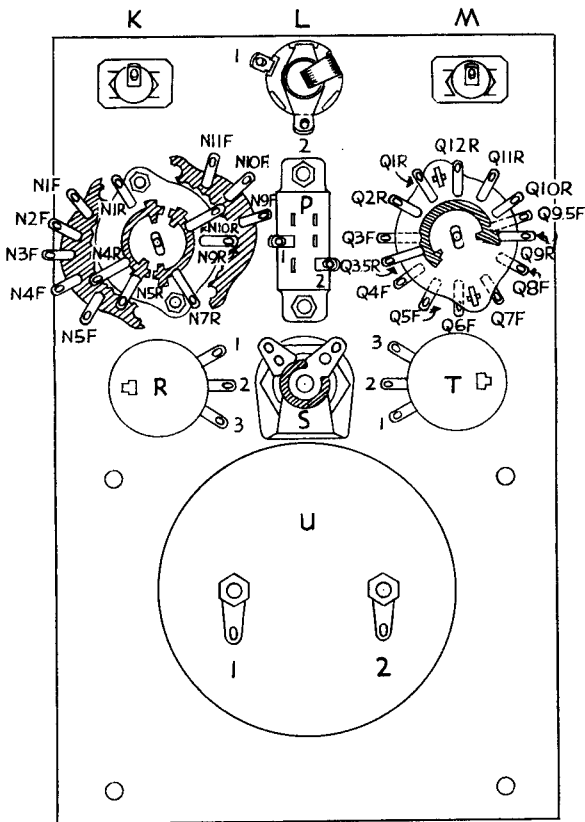

**Fig. 5**

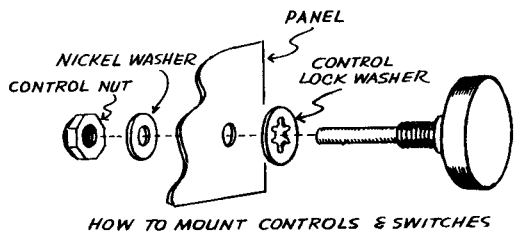

**Fig. 6**

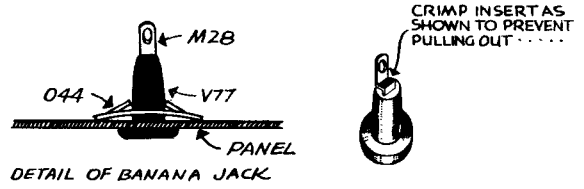

**Fig. 7**

- (✓) Mount the OFF-ON switch (O94) in position P using 6-32 screws, lockwashers and nuts. Make certain that the lugs protruding from the back are as shown (so as to not mount the switch upside down by mistake).
- (✓) Note Figure 7 and mount the black banana jack (V77B) in location K. Slip the insert (M28) into the jack.
- (✓) In a like manner, mount the red banana jack (V77R) in location M. Slip the insert (M28) into the jack.
- (✓) Consult Figure 8 and mount the phone jack assembly (K17, O101, O28, O33) in position L. Be sure the positioning of lugs is exactly as shown in Figure 5, otherwise shorting could occur when the unit is placed in the case.



- (✓) Consult Figure 9 and mount the pilot light assembly (O52, O40, O41, O42, O39) in position S.
- (✓) Mount a 10K control (V25) in position R. (Refer again to Figure 6 for mounting of controls and switches.)
- (✓) Mount the other 10K control in position T.
- (✓) Mount the two deck selector switch (V106) in location N.
- (✓) Mount the range switch (V75-3) in position Q.

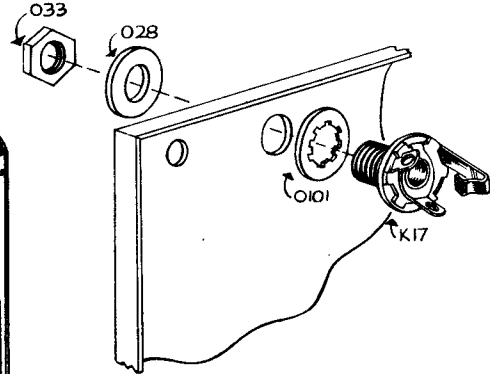
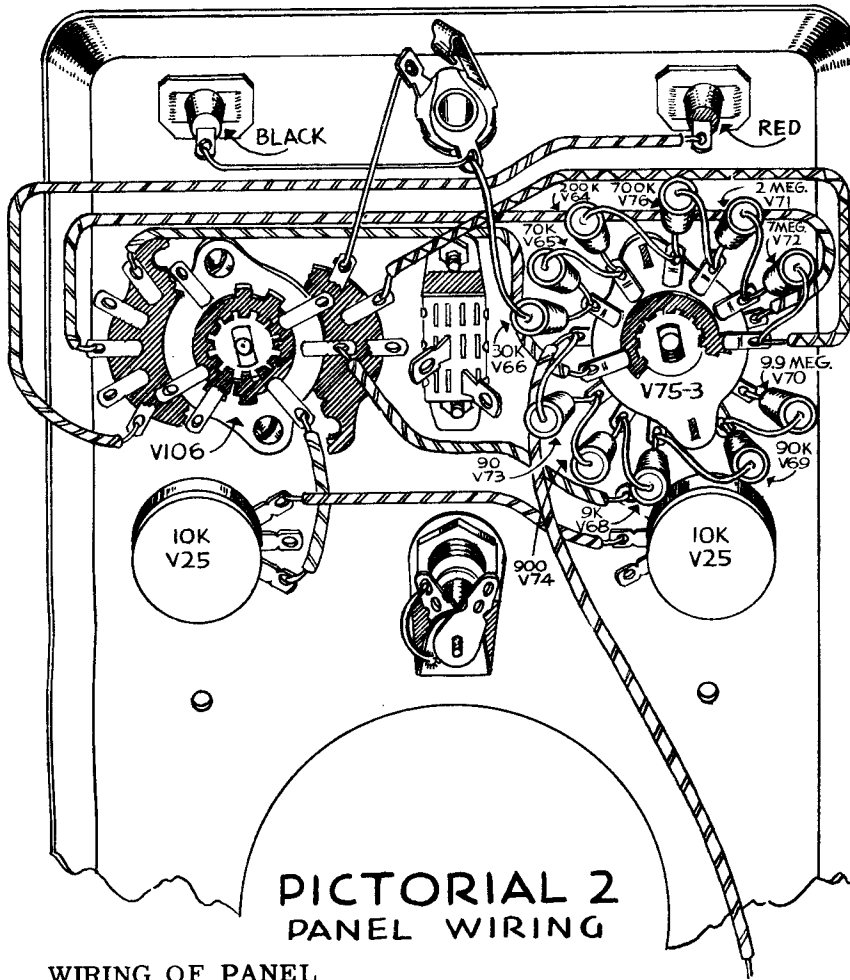

Fig. 8

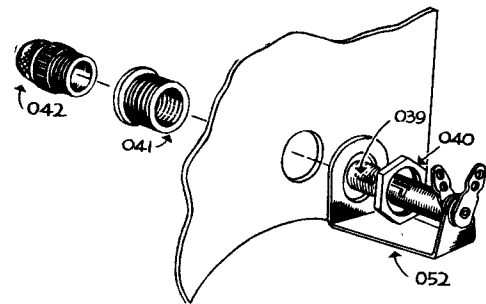

Fig. 9

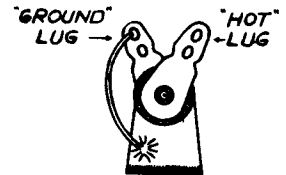

Fig. 10

Be certain to check with pictorial 2 for the best lead dress of panel wiring.

- Q1 (✓) Connect a short length of bare wire to the pilot light ground lug (S) and fasten the other end of the wire to the pilot light mounting frame (S). See Figure 10.
- Q2 (✓) Run a wire from N1F (S) to Q3.5R (S). *ok*
- Q3 (✓) Run a wire from N3F (S) to Q9.5F (S). *ok*
- Q4 (✓) Run a wire from N5F (S) to the red banana jack M insert lug (S). *ok*
- Q5 (✓) Run a wire from N7R (NS) to R3 (S). *ok*
- Q6 (✓) Run a wire from N9R (S) to T3 (S). *ok*
- Q7 (✓) Run a wire from N10F (S) to Q9R (NS). *ok*
- Q8 (✓) Run a short piece of stiff bare wire from N11F (S) to L1 (S). *ok*
- Q9 (✓) Run a wire from R1 (NS) to T2 (S). *ok*
- Q10 (✓) Run a short piece of stiff bare wire from (use spaghetti if necessary) L2 (NS) to the black banana jack K insert lug (S). *ok*
- Q11 (✓) Connect a 4" wire length to Q3F (NS) and leave the other end free. *ok*
- Q12 (✓) Connect one lead of the 30K resistor (V66) to Q2R (NS) (See Pictorial 2) and its other lead to L2 (S). (Note Figure 11) *ok*

- (✓) Connect the 70K resistor (V65) between Q2R (S) and Q1R (NS) *rk*
- (✓) Connect the 200K resistor (V64) between Q1R (S) and Q12R (NS) *rk*
- (✓) Connect the 700K resistor (V76) between Q12R (S) and Q11R (NS) *rk*
- (✓) Connect the 2 megohm resistor (V71) between Q11R (S) and Q10R (NS) *rk*
- (✓) Connect the 7 megohm resistor (V72) between Q10R (S) and Q9R (S) *rk*
- (✓) Connect the 9.9 megohm resistor (V70) between Q8F (S) and Q7F (NS) *rk*
- (✓) Connect the 90K resistor (V69) between Q7F (S) and Q6F (NS) *rk*
- (✓) Connect the 9K resistor (V68) between Q6F (S) and Q5F (NS) *rk*
- (✓) Connect the 900 ohm resistor (V74) between Q5F (S) and Q4F (NS) *rk*
- (✓) Connect the 90 ohm resistor (V73) between Q4F (S) and Q3F (S) *rk*

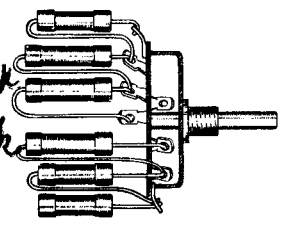
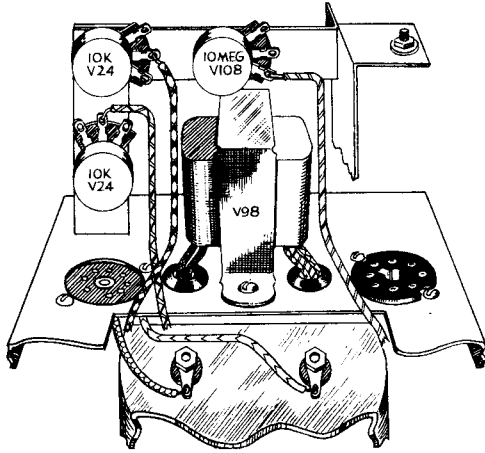
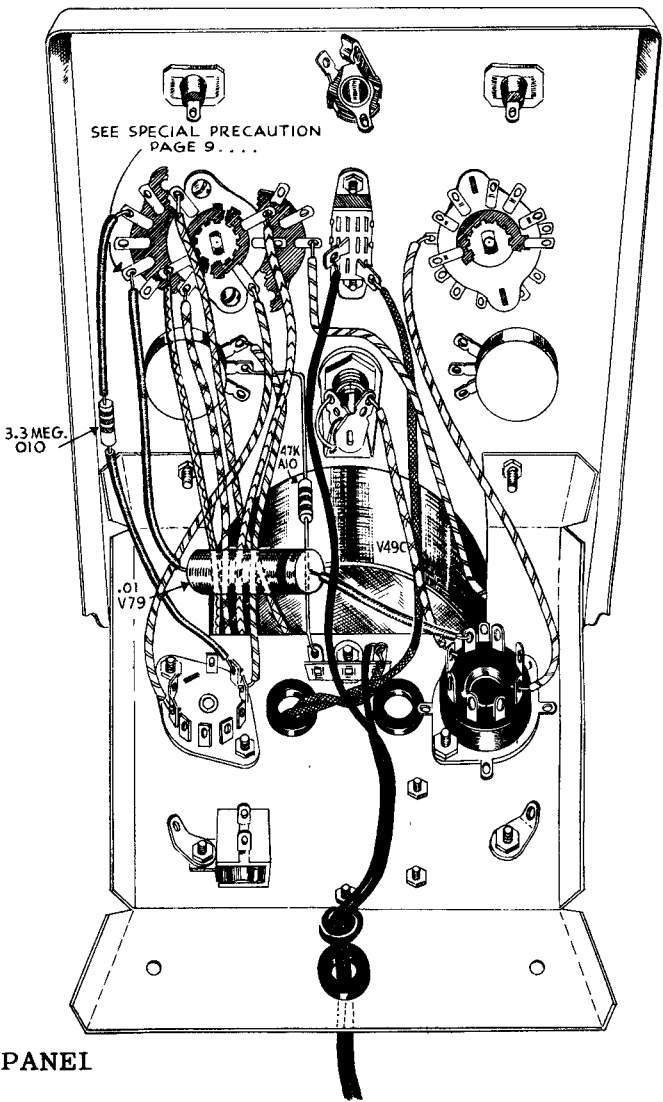

Fig. 11



PICTORIAL 3  
WIRING COMMON TO BOTH  
CHASSIS AND PANEL . . . .



WIRING COMMON TO BOTH CHASSIS AND PANEL

- (✓) Slide the meter (V49C) through the opening provided in the panel (location U). The four meter mounting screws will slide through the four holes provided. Check to see that the meter is placed correctly (not upside down). *rk*
- (✓) Now place the chassis against the panel as shown in pictorial 3, slip a lockwasher over each of the four meter mounting screws, and tighten a nut on each. *rk*
- (✓) Run a wire from R1 (S) to A3 (S). *rk*
- (✓) Connect one lead of a 47K resistor (A10) to (use spaghetti) R2 (S) and its other lead to C1 (S). *rk*
- (✓) Run a wire from N9F (S) to Z3 (S). *rk*
- (✓) Run a wire from N10R (S) to the meter terminal U2 (S). *rk*
- (✓) Run a wire from N4R (S) to the meter terminal U1 (S). *rk*



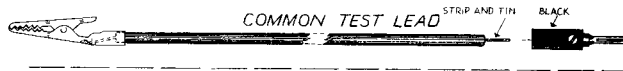

Fig. 12

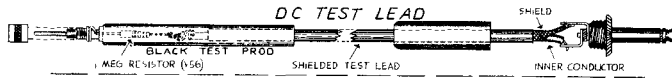

Fig. 13

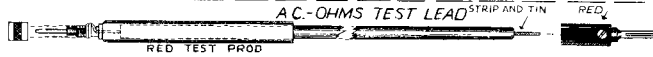

Fig. 14

(1) DC test lead. The DC test lead is made by connecting the phone plug (V41) on one end of the shielded test lead (V47). On the other end goes a small 1 megohm resistor (V56), which is then slipped inside the black test prod. See Figure 13.

( ) AC-Ohms test lead. The AC-Ohms test lead is made by connecting the red banana plug (V40) on one end of the red test lead (V46), and the red test prod (V42) on the other. Figure 14 shows the construction.

(L) Fasten the handle (O79) on the case (V112) using two 10-24 screws (O30).

( ) Push the rubber feet (O34) into the four holes in the bottom of the case.

(See Figure 15.)



Fig. 15

(V) Slide the acorn knobs (V48) over the shafts of the zero adjust and ohms adjust controls and tighten down the small set screw in each.

(V) Turn both switches maximum counterclockwise and slide the two pointer knobs (O51) over the shafts and tighten down the small set screw while the pointer knobs are indexed properly (ie pointing correctly).

(V) Plug the 6H6 in socket E and the 12AU7 in socket A. (See warning below)

This completes the wiring of the kit and the instrument is now ready to test and calibrate.

### IMPORTANT WARNING

Miniature tubes can be easily damaged when plugging them into their sockets. Therefore, use extreme care when installing them. WE DO NOT GUARANTEE OR REPLACE MINIATURE TUBES BROKEN DURING INSTALLATION.

### TEST AND CALIBRATION

Check over the wiring carefully. We suggest tracing over each wire on the pictorial with a colored pencil as it is checked on the instrument. Check each solder connection. Install the tubes.

Plug the instrument into a 117 Volt 50/60 Cycle AC ONLY outlet. This instrument will not operate, and serious damage will result, if plugged into a DC outlet.

Turn the switch on and allow a minute for warm up. Set the selector switch to DC+. Check operation of zero adjust control. Turning this control should move the meter pointer to about half or  $\frac{3}{4}$  scale and to zero. Set pointer to zero and check if it remains on zero when switched to DC-. If there is appreciable zero shift (more than one or 2 divisions on the scale) the tubes must be aged. First complete the initial test, however.

Turn the instrument off and make sure the mechanical zero of the meter is correct. If not, adjust as follows: Place the instrument in normal operating position. (This usually is with the rubber feet on a level surface.) Turn the black plastic screw on the meter face with a screwdriver, while gently tapping the meter face with one finger, until the pointer coincides with the zero line on the left side of the scale. Turn the instrument on again.

Insert the common and DC test leads. Set the selector switch to DC+ and the range switch to 3V. Connect the test leads to the calibrated flashlight cell, and adjust the DC calibrate control (See Figure 16) so the meter pointer indicates the calibration voltage on the 3V scale. The reading will be close to that shown in figure 17, ie. 30 on the 3V range means full scale is actually 3V. Therefore, 15.5 for example, is a voltage of 1.55 volts.

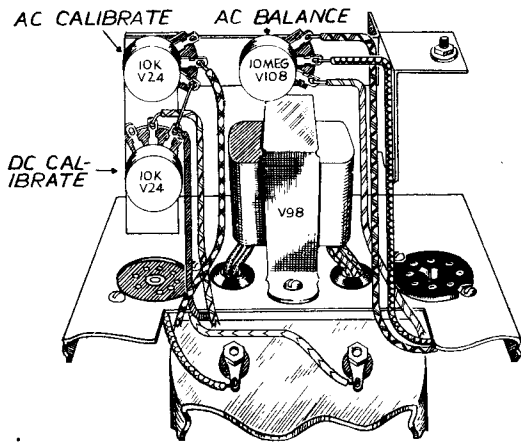

Fig. 16

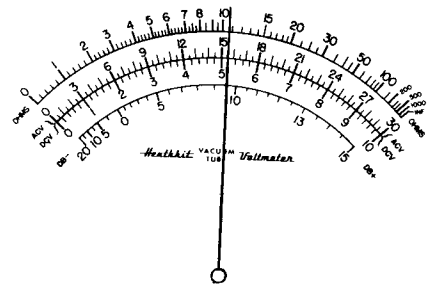

Fig. 17

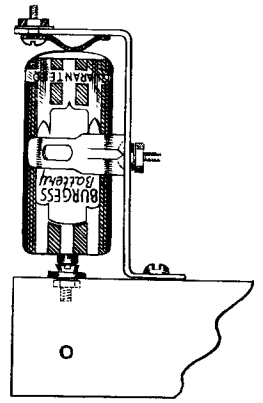

Fig. 18

Install the battery in the battery bracket as shown. Now place the instrument in the case, but leave off the rear cover. Set selector switch to ohms. Pointer should swing to about full scale. Turn ohms adjust to give full scale reading (INFinite). Insert AC ohms test lead. Touch this lead to common lead and observe pointer dropping to zero indicating short circuit (no resistance).

Temporarily remove AC-ohms test lead. Set range switch to 3V, and selector to AC. Adjust AC balance control so no movement is noticed in the pointer when switching from AC through DC- to DC+. Now set range switch to 300V. Re-insert AC ohms lead. Connect AC ohms and common lead to the 117V AC line (NOTE: 117 Volt line is dangerous—proceed with due care) and adjust AC calibrate control so pointer indicates the line voltage.

It is recommended that the tubes be aged before final calibration. This is accomplished by keeping the instrument turned on for a period of at least 48 hours. Final calibration should be done in the same way as the initial calibration. Careful calibration will result in a more accurate instrument. If a standard AC meter is available, it is desirable to use such an instrument, preferably at a voltage near full scale indication on the VTVM, as for instance 250 Volt or 90 Volt (on the 300V or 100V scale respectively).

If, after a period of about 72 hours, the AC balance control cannot keep the pointer from moving when switching from AC through DC- to DC+ (with the range switch at 3V), the diode connections should be reversed. This should be done as shown below.

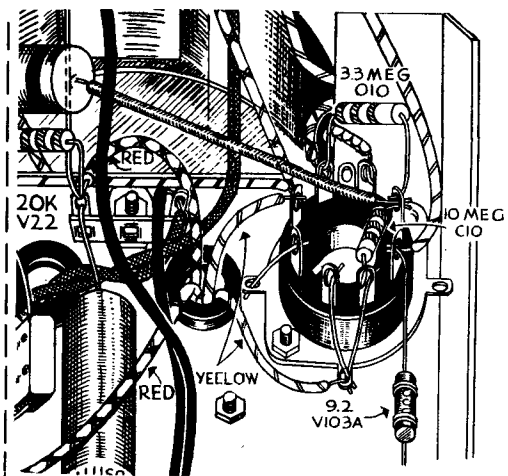
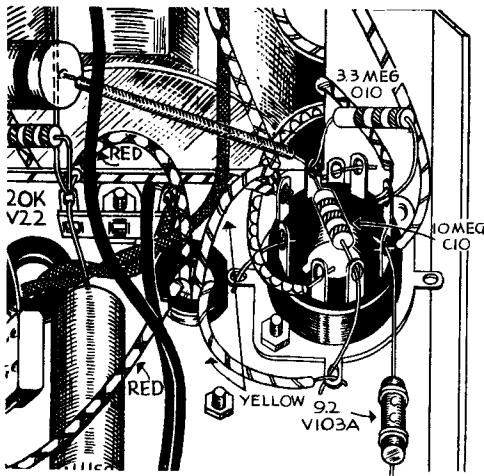

STANDARD CONNECTIONS | DIODES REVERSED  
FOLLOW COLOR CODING TO MAKE THE CHANGE

After final calibration, place the rear cover (V111) on the case, and install two sheet metal screws through the back and into the chassis. The instrument is now ready for use.

## CIRCUIT DESCRIPTION

This instrument uses a balanced vacuum tube circuit to increase the sensitivity and provide greater flexibility. The relationship between the test voltage applied to the tube and the indicating meter current is linear over a range appreciably greater than the operating range. When a much larger test voltage is accidentally applied, the relationship ceases to be linear and the indicating meter current is limited to a value of a few times full scale current. Thus the meter movement, when used in this circuit, is protected. Repeated overloads should be avoided, however, as the pointer may be bent.

The zero adjust control balances the currents through the tubes and permits the meter to be set to zero, or partly up scale.

The calibration controls are in series with the meter and are adjusted to produce full scale reading with the proper test voltage applied to the instrument. The maximum test voltage applied to the tube is about 3 Volts. Higher test voltages are reduced by a voltage divider with a total resistance of 10 megohms. An additional resistor of 1 megohm is located in the DC test prod, which permits measurements to be made in circuits carrying R.F. with minimum disturbance of such circuits.

For AC voltages in the Audio Frequency range, a shunt fed diode is used to provide a DC voltage proportional to the peak of the applied AC voltage. This DC voltage is applied through the voltage divider to the tube, causing the meter to indicate. The AC calibrate control is used so as to obtain the proper meter deflection for the applied AC voltage. Vacuum tubes develop a contact potential voltage between tube elements. Such contact potential developed in the diode would cause a slight voltage to be present at all times. This voltage is cancelled out by bucking it with a portion of the contact potential of a second diode. The amount of bucking voltage is controlled by the AC balance control. This eliminates zero shift when switching from DC to AC.

For resistance measurements, a battery is connected through a string of multipliers to the tube. The external resistance to be tested is connected between tube and common (chassis), forming, together with the multipliers, a voltage divider across the battery. The resultant portion of the battery voltage is thus applied to the tube causing the meter to deflect. The meter scale is calibrated in resistance.

## USING THE VTVM

**NOTE:** As the heaters are operated at a low temperature, the tube life is extremely long. The power consumption is very low. We therefore recommend that this instrument be turned on at the same time as the soldering iron for instance, and left on until the work is done. This will result in very stable operation, and the slight amount of heat generated inside the cabinet will keep the instrument free from moisture in humid climates.

The VTVM has many advantages over the non-electronic volt-ohmmeters. The greatest advantage is the high input resistance. This enables much more accurate readings to be obtained in high impedance circuits, such as resistance coupled amplifiers, oscillator grid circuits and AVC networks.

To illustrate this, let us assume a resistance coupled audio amplifier with a .5 megohm plate load resistor, operating with a 100 Volt plate supply. Let us also assume that the plate voltage is 50 Volts and that, therefore, the tube acts as a .5 megohm resistor. Measuring the plate voltage with a conventional 1,000 ohm per volt instrument on the 100 Volt scale, the meter can be considered a 100,000 ohm (.1 megohm) resistor in parallel with the tube. The voltage on the plate is then about 14 Volts and is shown as such by the meter. This is due to the shunt resistance of the low resistance meter. Using the VTVM on any scale setting, the full 11 megohms is placed in parallel with the tube. The voltage on the plate is then about 49 Volts or 2% lower than the normal operating voltage. Thus accurate reading can only be obtained with the high resistance provided by a VTVM.

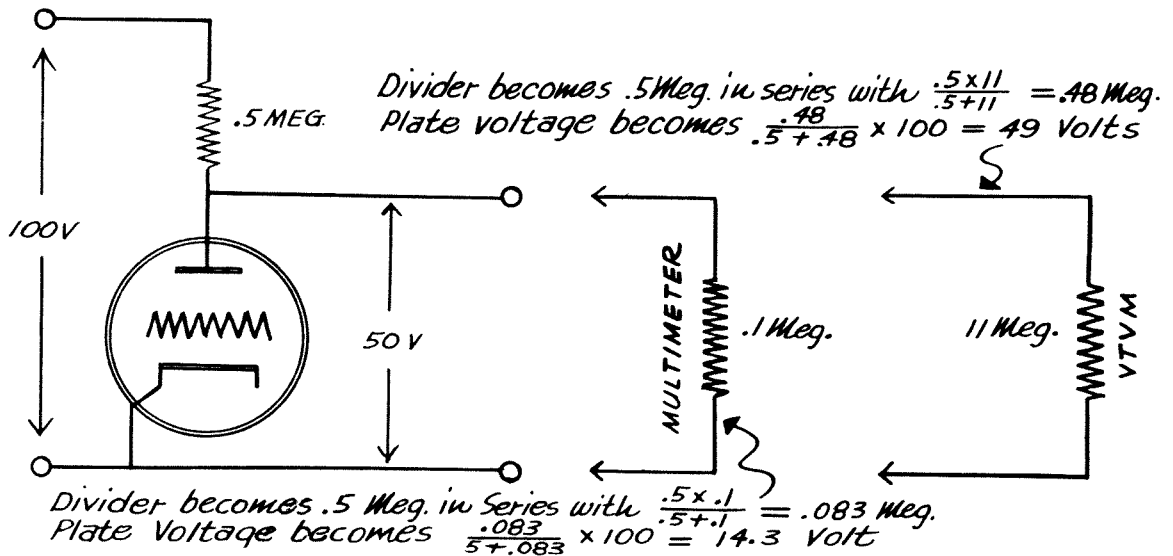

An understanding of the characteristics of your instrument will result in greater satisfaction through proper use.

#### DC VOLTAGE

To measure DC voltage with the VTVM, connect the common (black) lead to the common or "cold" side of the voltage to be measured. Set the selector switch to DC+ or DC- as required, and set the range switch to a range greater than the voltage to be measured, if known. If unknown, set to 1,000 Volts. With black test prod, touch other or "hot" side of the voltage to be measured. If pointer moves less than one-third of full scale, switch to the next lower range.

#### AC VOLTAGE

To measure AC voltage with the VTVM, connect the common (black) lead to the common or "cold" side of the voltage to be measured. Set the selector switch to AC, and set the range switch to a range greater than the voltage to be measured, if known. If unknown, set to 1,000 Volts. With red test prod, touch other or "hot" side of the voltage to be measured. If pointer moves less than one-third of full scale, switch to the next lower range.

The Heathkit is an extremely sensitive electronic AC voltmeter and as the human body picks up AC when near any AC wires, the meter will indicate this pickup. Never touch the AC prod when on the lower ranges. Zero should be set with the AC prod shorted to the common clip.

#### RESISTANCE

To measure resistance with the VTVM, connect the common (black) lead to one side of the resistor to be measured. Set the selector to ohms, and set the range switch to such a range that the reading will fall as near to mid-scale as possible. Set the ohms adjust control so the meter indicates exactly full scale (INF. on ohms scale). Then touch the red test prod to the other side of the resistor to be measured. Read resistance on ohms scale and multiply by the proper factor as shown by the range switch setting.

NOTE: Although batteries are used to measure resistance, the indication is obtained through the electronic meter circuit, and therefore, the instrument must be connected to the AC power line and tuned on.

CAUTION: Never leave the instrument on ohms, as it greatly shortens the life of the ohmmeter battery.

## USING THE VTVM DECIBEL SCALE

Because the human ear does not respond to volume of sound in proportion to signal strength, a unit of measure called the "bel" was adopted. The "bel" is more nearly equivalent to human ratios. Normally the reading is given in 1/10 of a "bel" or "decibel."

Various signal levels are adopted by various manufacturers as standard or "O" decibels.

The Heathkit VTVM DB scale uses a standard of 6 milliwatts into a 500 ohm line as "O" decibels. This corresponds to 1.73 VAC on the 0-10 scale. From this figure, the various AC ranges of the VTVM may be converted to db by the following chart

AC VOLTS SCALE	DECIBEL SCALE
0-3V	Subtract 10 db from reading
0-30V.	Add 10 db to the reading
0-100V.	Add 20 db to the reading
0-300V	Add 30 db to the reading
0-1000V	Add 40 db to the reading

As the decibel is a power ratio or voltage ratio, it may be used as such without specifying the reference level. Thus for instance, a fidelity curve may be run on an amplifier by feeding in a signal of variable frequency but constant amplitude. At a reference frequency of say 400 cycles, adjust input to give a convenient indication (0 db for instance) on the VTVM connected to the output. As the input frequency is varied, the output level variation may be noted directly in db above and below the specified reference level.

**NOTE:** When measuring complex AC wave shapes, such as ripple, hum, distorted and square waves, the indication is 70% of the positive peak.

### READING THE METER SCALE

The voltage markings on the range switch refer to the FULL SCALE reading. The scale is marked 0-10 and 0-30 for voltage. On the 3 Volt range, read the 0-30 scale and drop the zero. On the 10 Volt range, read the 0-10 scale directly. On the 30 Volt range, read the 0-30 scale directly. On the 100 Volt range, read the 0-10 scale and add one zero. On the 300 Volt range, read the 0-30 scale and add one zero. On the 1,000 Volt range, read the 0-10 scale and add two zeros.

**NOTE:** This marking does not mean that the upper scale indicates ACV and the lower scale DCV. Rather, it means that either scale will read ACV or DCV, depending on the setting of the selector switch.

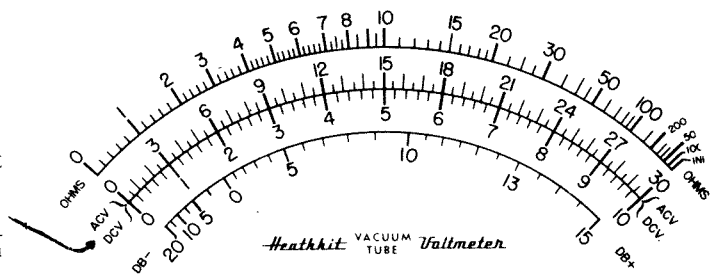

The resistance marking or ohms scale refers to the lowest resistance range (Rx1). For the other ranges, add the proper number of zeros (add two zeros for Rx100, add four zeros for Rx10K, add six zeros for Rx1 Meg). On the Rx1 Meg range, the scale can also be considered to read directly in megohms.



## ACCURACY

The accuracy of the meter movement is within 2% of full scale, which means that, for instance on the 1000 Volt range the accuracy of the movement will be within 20 Volts at any point on the scale. On DC, the accuracy of the multiplier (1%) may be additive, resulting in an accuracy of within 3% of full scale.

On AC, the accuracy of the rectifier circuit contributes variations which result in accuracy of within 5% of full scale.

The accuracy on the ohms ranges depends on the meter accuracy, the ohms multiplier accuracy (including the internal resistance of the batteries), and the stability of the battery voltage. On the Rx1 scale, the internal resistance of the batteries and the battery voltage both vary as result of the current drawn by the resistance under test. For greatest accuracy, tests on low resistance values should be made as quickly as possible. On the higher ohms ranges, the accuracy depends practically on the multipliers, which are 1%, and the meter movement accuracy. Because of the non-linear ohms scale, the resulting accuracy is not readily expressed in a percentage figure, but the greatest accuracy is obtained at mid-scale readings.

NOTE: When comparing this instrument with another instrument, consider that the accuracy of the other instrument may deviate in the opposite direction. Therefore, when comparing two instrument of 5% accuracy, the difference might be a total of 10%. Critical comparisons should only be made against certified laboratory standards.

### IN CASE OF DIFFICULTY

1. Recheck the wiring. Most cases of trouble result from wrong or reversed connections. Often having a friend check the wiring will reveal a mistake consistently overlooked.

2. Check the tubes.

The possibility exists that a perfectly balanced tube will not permit Zero center adjustment on either DC+ or DC-. Then add 1000 ohms or more in series with either 12AU7 cathodes and the Zero adjust control.

3. If the pointer swings full scale to the right and stays there with switch set to DC+, check for an open circuit or high resistance connection somewhere between the grid pin #2 of the 12AU7 and ground. This might be due to a wrong connection to the selector switches, a poor connection, or possibly an open resistor.

If the instrument does not operate on any function, a check of the power supply, and the 12AU7 and its associated meter circuit is suggested.

If the instrument only fails to function on AC measurements, then a check of the 6H6 and its associated circuits should be made.

If the instrument only fails to function on ohms, the difficulty will probably be due to the battery (make certain the battery is making good contact in the bracket) or the ohms multipliers.

Proper operation on DC should first be secured before an attempt is made to use the instrument on AC or ohms.

4. Check the operating voltages. The following voltages are measured to chassis: Pin #1 or #6 on 12AU7 tube or + lug on rectifier 40-70 Volts positive. Negative lug on rectifier 60-100V negative. Pin 2 of 6H6 and pin 9 of 12AU7, 5-6V AC.

5. Check continuity through the DC test cable. Make certain that the shielding is not shorted to center conductor.

## SERVICE

In event continued operational difficulties of the completed instrument are experienced, may we remind you that the Heath Company has provided a technical consultation service. Every effort will be made to assist you through correspondence. We emphasize that in all correspondence this instrument should be referred to as the Model V-5A VACUUM TUBE VOLTMETER.

The facilities of the Heath Company Service Department are also available. Your instrument may be returned for inspection, repair, and calibration for a service charge of \$ 3.00 plus the cost of any additional material that may be required. This service policy applies only to completed instruments constructed in accordance with the instructions as stated in the manual. Instruments that are not completed or instruments that are modified will not be accepted for repair. Instruments showing evidence of acid core solder or paste fluxes will be returned not repaired.

The Heath Company is willing to offer its utmost cooperation to assist you in obtaining proper operation of your instrument. The repair service is available until one year from the date of purchase.

**NOTE:** Before returning this unit, be sure all parts are securely mounted. Attach a tag to the instrument giving name, address and trouble experienced. Pack in a rugged container, preferably wood, using at least three inches of shredded newspaper or excelsior on all sides. Do not ship in original carton only as this carton is not considered adequate for safe shipment of the completed instrument. Ship by prepaid express, if possible. Return shipment will be made by express collect. Note that a carrier cannot be held liable for damage in transit if packing, in his opinion, is insufficient.

Prices are subject to change without notice. The Heath Company reserves the right to change the design without incurring liability for equipment previously supplied.

## BIBLIOGRAPHY

Many excellent articles on the construction and use of vacuum tube voltmeters have appeared in radio magazines. A few are:

- RADIOCRAFT, June, 1945, Electronic Ohmmichecker
- RADIO NEWS, January, 1947, Home Constructed VTVM
- RADIO NEWS, July, 1946, Vacuum Tube Voltmeter
- RADIO NEWS, November, 1945, Electronic Volt-ohmmeter
- RADIO NEWS, February, 1946, Universal Test Instrument
- RADIOCRAFT, May, 1945, Practical VTVM
- VACUUM TUBE VOLTMETERS, A Book by John F. Rider

## RF TEST PROBE KIT

A test probe in kit form for use in measuring RF voltages of up to about 20 Volts is available for \$5.50. The kit contains all parts necessary for the construction of the probe, including 1N34 crystal detector, condensers, resistor, cable and connectors. This probe and cable is simply plugged into the instrument in place of the regular DC test probe assembly and the voltage is read on the lower regular DC ranges.

Order No. 309 RF Test Probe Kit—\$5.50

## TELEVISION TEST PROBE KIT

A 30,000 volt test probe in kit form for use in testing the high DC voltage in Television receivers is available for \$5.50. The kit contains all parts necessary for the construction of the probe, such as the precision multiplier of 2% accuracy, the molded red and black body and handle, the connectors and the cable. This probe and cable is simply plugged into the instrument in place of the regular DC test probe and with the range switch set at 300 volt, 0 - 30,000 volts is read on the 0 - 30 scale. With range switch set a 100 volt or 30 volt, the instrument reads 0 - 10,000 volts on the 0 - 10 scale and 0 - 3,000 volts on the 0 - 30 scale.

Order No. 336 TV High Voltage Probe Kit—\$5.50

Prices subject to change without notice. The Heath Company reserves the right to change the design of its instruments without incurring liability for equipment previously supplied.

#### WARRANTY

The Heath Company limits its warranty on any part supplied with any Heathkit (except tubes, meters, and rectifiers, where the original manufacturer's guarantee only applies) to the replacement within three (3) months of said part which, when returned with prior permission, postpaid, was, in the judgment of the Heath Company, defective at the time of sale.

The assembler is urged to follow the instructions exactly as provided. The Heath Company assumes no responsibility nor liability for any damages or injuries sustained in the assembly of the device or in the operation of the completed instrument.

HEATH COMPANY  
Benton Harbor, Michigan

## V-5A VACUUM TUBE VOLTMETER PARTS LIST

Part No.	Parts Per Kit	Description	Part No.	Parts Per Kit	Description
<b>Resistors</b>			<b>Hardware</b>		
V103A	1	9.2 Ohm Precision	G31	2	4-40 x 1/4 Screws ✓
V73	1	90 Ohm Precision	MT12	2	4-40 Nuts ✓
V74	1	900 Ohm Precision	SW34	2	3-48 x 1/4 Screws ✓
V68	1	9K Ohm Precision	SW35	2	3-48 Nuts ✓
V66	1	30K Ohm Precision	O31	10	6-32 x 3/8 Screws ✓
V65	1	70K Ohm Precision	K43	1	6-32 x 1/2 Flat Head Screws ✓
V69	1	90K Ohm Precision	O102	2	#6 x 3/8 Sheet Metal Screws ✓
V64	1	200K Ohm Precision	O30	2	10-24 x 3/8 Handle Screws ✓
V76	1	700K Ohm Precision	S22	10	6-32 Nuts
V71	1	2 Megohm Precision	O33	8	Control Nuts ✓
V72	1	7 Megohm Precision	TS72	11	#6 Lockwashers ✓
V70	1	9.9 Megohm Precision	O101	8	Control Lockwashers ✓
V23	1	15K	O28	5	Control Nickel Washers ✓
V22	1	20K	O44	2	Speednuts for Jacks ✓
A10	1	47K	O37	2	Solder Lugs ✓
V56	1	1 Megohm	O35	3	3/8 Grommets
O10	2	3.3 Megohm	O34	4	Rubber Feet
C10	2	10 Megohm	V114	1	Battery Spring Clamp ✓
<b>Condensers</b>			V117	1	Control Mtg. L Bracket (Long) ✓
V26	1	.003 MFD	V118	1	Control Mtg. L Bracket (Short)
V79	1	.01 MFD 2,000 Volt	V119	1	Battery Mtg. Z Angle Bracket
V27	1	12 MFD 150 Volt	<b>Wire--Plugs--Prods--Clips</b>		
<b>Controls</b>			O77	1	Roll Hookup Wire
V24	2	10K Ohms (AC & DC calibrate) ✓	O81	1	Length Spaghetti
V25	2	10K Ohms (Ohms & Zero Adjust)	V46	1	Length Red Test Lead 3 Ft.
V108	1	10 Megohm (AC balance)	V45	1	Length Black Test Lead 3 Ft. ✓
<b>Switches</b>			V47	1	Length Shielded Test Lead 3 Ft.
V106	1	Selector ✓	O78	1	Line Cord
V75-3	1	Range ✓	V40	1	Red Banana Plug ✓
O94	1	SPST Slide ✓	V39	1	Black Banana Plug ✓
<b>Sockets--Terminal Strips--Jacks--Fiber Washers</b>			V41	1	Phone Plug
V113	1	Miniature Socket (9 pin) ✓	V42	1	Red Test Prod
V122	1	Octal Socket ✓	V43	1	Black Test Prod
O52	1	Pilot Light Socket	V44	1	Alligator Clip
O40	1	Pilot Light Nut	V124	1	Battery Base Clip ✓
O41	1	Pilot Light Bushing	<b>Miscellaneous</b>		
O42	1	Pilot Light Jewel ✓	V48	2	Acorn Knobs ✓
S32	1	2 Lug Terminal Strip	O51	2	Pointer Knobs
V77R	1	Banana Jack (red)	V49C	1	200 Microamp. Meter ✓
V77B	1	Banana Jack (black)	M39	1	Flashlight Cell (Calibrated) ✓
M28	2	Banana Jack Inserts ✓	V123	1	Selenium Rectifier ✓
K17	1	Phone Jack	V98	1	Power Transformer ✓
BE22	1	1/4 Fiber Sholder Washer #8 ✓	V116	1	Chassis ✓
O27	1	9/64 Plain Fiber Washer ✓	O79	1	Handle ✓
<b>Tubes--Lamp</b>			V110	1	Front Panel ✓
V31	1	6H6 Tube ✓	V111	1	Rear Cover
V121	1	12AU7 Tube ✓	V112	1	Case ✓
O39	1	#47 Pilot Lamp			



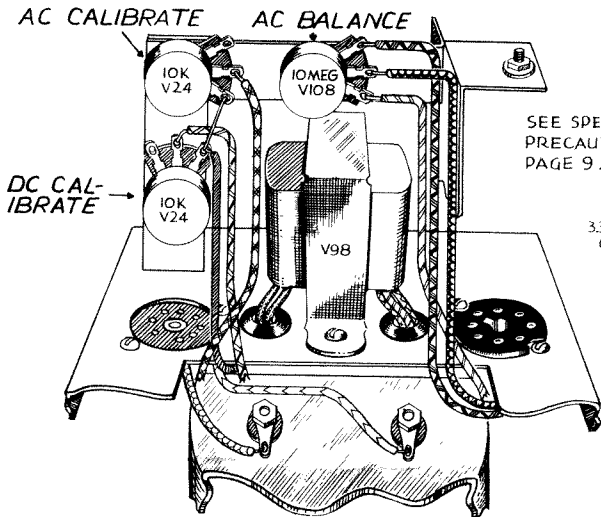

SEE SPECIAL PRECAUTION PAGE 9....

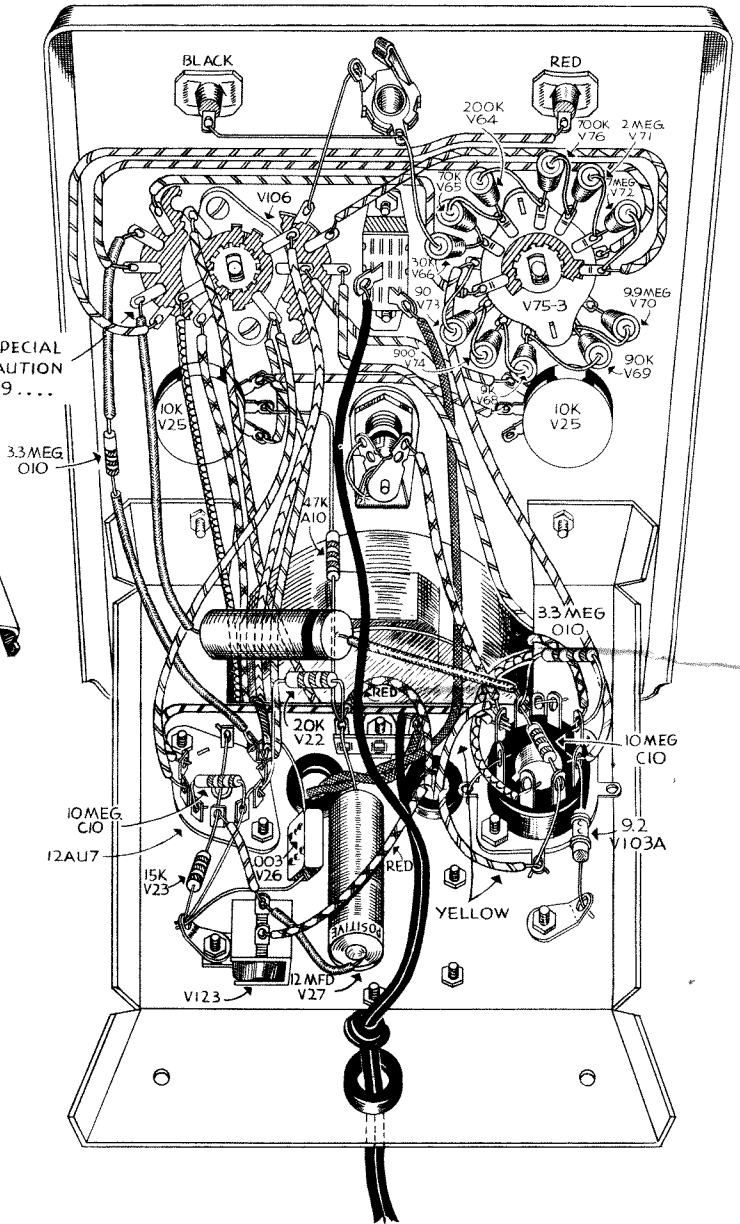

**PICTORIAL 4**  
WIRING OF COMPLETED INSTRUMENT....

# RMA Color Code on Transformers

## I.F. TRANSFORMERS

Blue — Plate Lead  
 Red — B + Lead  
 Green — Grid  
 Black — Ground or AVC

If center tapped other grid is green and black striped

## AUDIO TRANSFORMERS

Blue — Plate Lead  
 Red — B + Lead  
 Brown — Other Plate on Push Pull  
 Green — Grid Lead  
 Black — Ground Lead  
 Yellow — Other Grid on Push Pull

## POWER TRANSFORMERS PRIMARY — BLACK

High Voltage Plate — Red  
 Center Tap Red and Yellow Striped  
 Rectifier Filament — Yellow  
 Center Tap Yellow and Blue  
 Filament No. 1 — Green  
 Center Tap Green and Yellow  
 Filament No. 2 — Brown  
 Center Tap — Brown and Yellow  
 Filament No. 3 — Slate  
 Center Tap — Slate and Yellow

## Soldering

The most important thing in good soldering is to heat the joint and allow the solder to flow into it. The solder should melt from contact with the joint rather than with the iron. Never use pastes or acids in radio work.

Use only rosin core solder. Never depend on the solder to hold a joint. Always make a firm connection with the wire before applying solder. To tin a soldering iron (soldering cannot be done with the bare copper) file the surface lightly while the iron is hot and then quickly apply a generous amount of rosin core solder while the filed surface is still bright. Wipe off excess solder with a cloth.

Tin all four sides of the tip in this manner.

























The terminals must be clean, and preferably tinned. On some terminals that are hard to solder to (nickel plated f.i.) it is desirable to pre-tin the surface before installation or connection. Clean (scrape or sandpaper) the surface, heat with iron and apply rosin core solder liberally. Wipe off or shake off excess solder.

## Recommended Tools

A good electric soldering iron (100 watt with small tip)  
 Long or needle nose pliers 6".  
 Diagonal or side cutting pliers (5" or 6").  
 An assortment of screw drivers flat and Phillips type.

File. Round and flat types.  
 Purchase quality tools and you will enjoy and use them many years.  
 American Beauty soldering irons, Plomb, and Williams pliers are recommended.

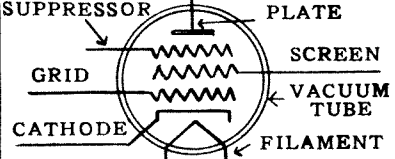
## Symbols Used in Radio Circuits

	ANTENNA OR AERIAL		VARIABLE CONDENSER		QUARTZ CRYSTAL
	CHASSIS OR GROUND		ELECTROLYTIC CONDENSER SHOWING POLARITY		CONNECTION OF TWO WIRES
	AIR CORE COIL		SWITCH		NO CONNECTION
	AIR CORE TRANSFORMER OR COIL		ROTARY SWITCH		FUSE
	R.F. CHOKE		SPEAKER		PHONE PLUG
	FILTER OR IRON CORE CHOKE . . .		METER	K =	1000
	IRON CORE TRANSFORMER		PILOT LIGHT	M =	1,000,000
	FIXED RESISTOR		PHONE JACK		OHM.
	VARIABLE RESISTOR OR POTENTIOMETER			MF =	MICROFARAD
	FIXED CONDENSER			MMF =	MICRO MICROFARAD

THE HEATH COMPANY . BENTON HARBOR, MICH.

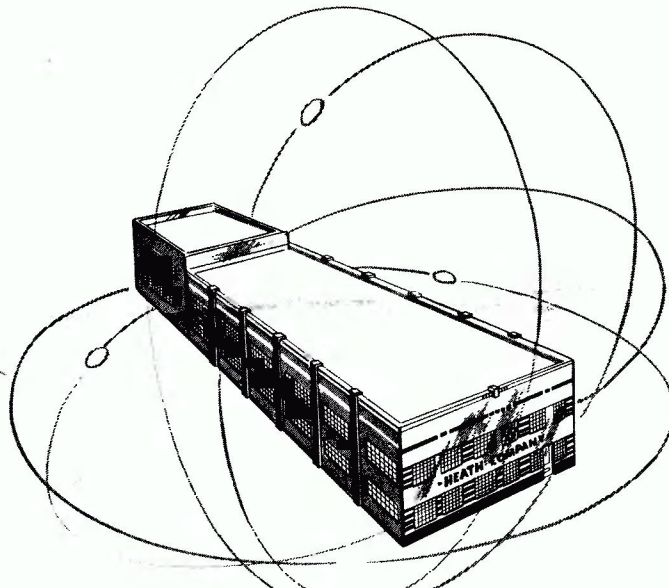

**THE HEATH COMPANY  
BENTON HARBOR, MICH.**



# **K4XL's** **BAMA**

This manual is provided **FREE OF CHARGE** from the “BoatAnchor Manual Archive” as a service to the Boatanchor community.

It was uploaded by someone who wanted to help you repair and maintain your equipment.

If you paid anyone other than BAMA for this manual, you paid someone who is making a profit from the free labor of others without asking their permission.

You may pass on copies of this manual to anyone who needs it. But do it without charge.

Thousands of files are available without charge from BAMA. Visit us at <http://bama.sbc.edu>